

Cloudy calculation of Accretion disk in Symbiotic Star (CASS)

Ho-Gyu Lee (KASI)



ABSTRACT

Symbiotic star is a system composed of a hot component (mostly white dwarf) and a cool component (usually giant). The material from mass losing giant flows to white dwarf probably forming an accretion disk around the hot star. An interesting observational finding is a detection of double peak profile of Raman scattered O VI 6825A line which originates from Raman scattering of O VI 1032A by neutral hydrogen. This can be explained by a rotating O VI accretion disk around a hot white dwarf. Here, we perform cloudy calculations assuming simple geometry of the system varying hydrogen density.

SYMBIOTIC STAR

(Unrelaxed) binary star spectroscopically classified by coexistence of cool, hot features and various emission lines.

- S type
 - Orbital period of hundreds days
 - Separation of ~ AU
- D type
 - Orbital period of several decades
 - Separation of tens of AU

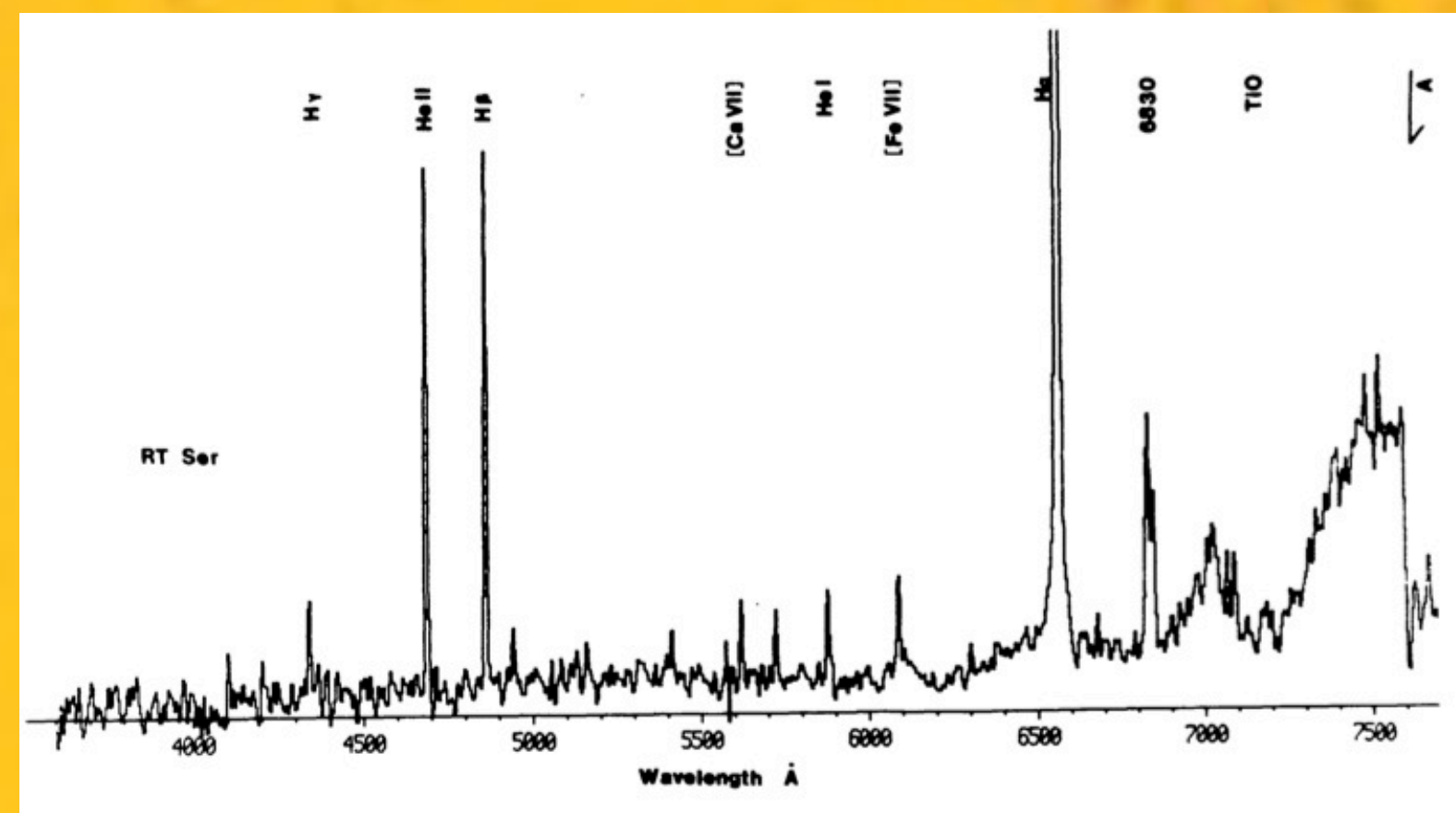

Artistic illustration (NASA)

Example spectrum (Allen 1983 Ap&SS, 99, 101)

CLOUDY INPUTS

- Central hot white dwarf
 - Blackbody 10^5 K and Luminosity 10^{37} erg s^{-1}
- Inner edge of accretion disk
 - Radius 10^{12} cm
- Uniform density structure
 - Varying H density $10^2 - 10^{10}$ cm^{-3}
- Cosmic rays background
- Iterate twice (2)

RAMAN SCATTERING

- Inelastic scattering
 - Energy difference absorbed by the scatterer
- Broad Raman scattered O VI 6825 & 7082 from O VI 1032 & 1038

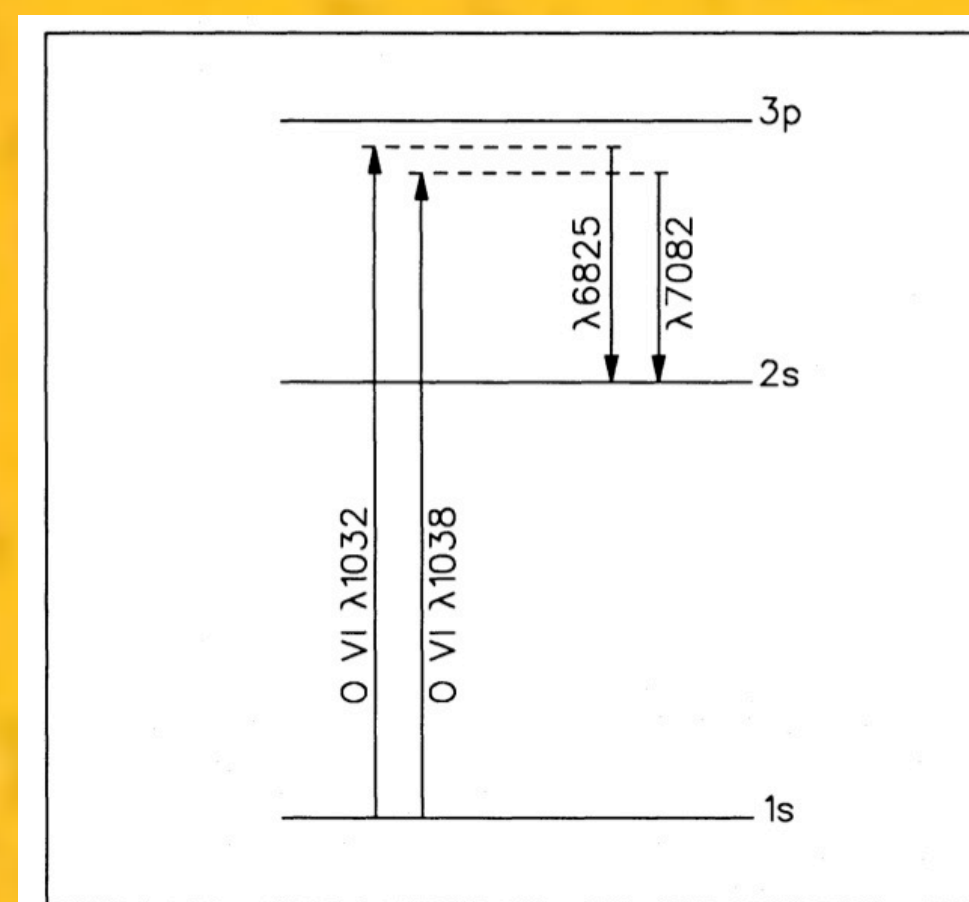

Fig.2. Schematic energy level diagram for Raman scattering of O VI photons by neutral hydrogen.

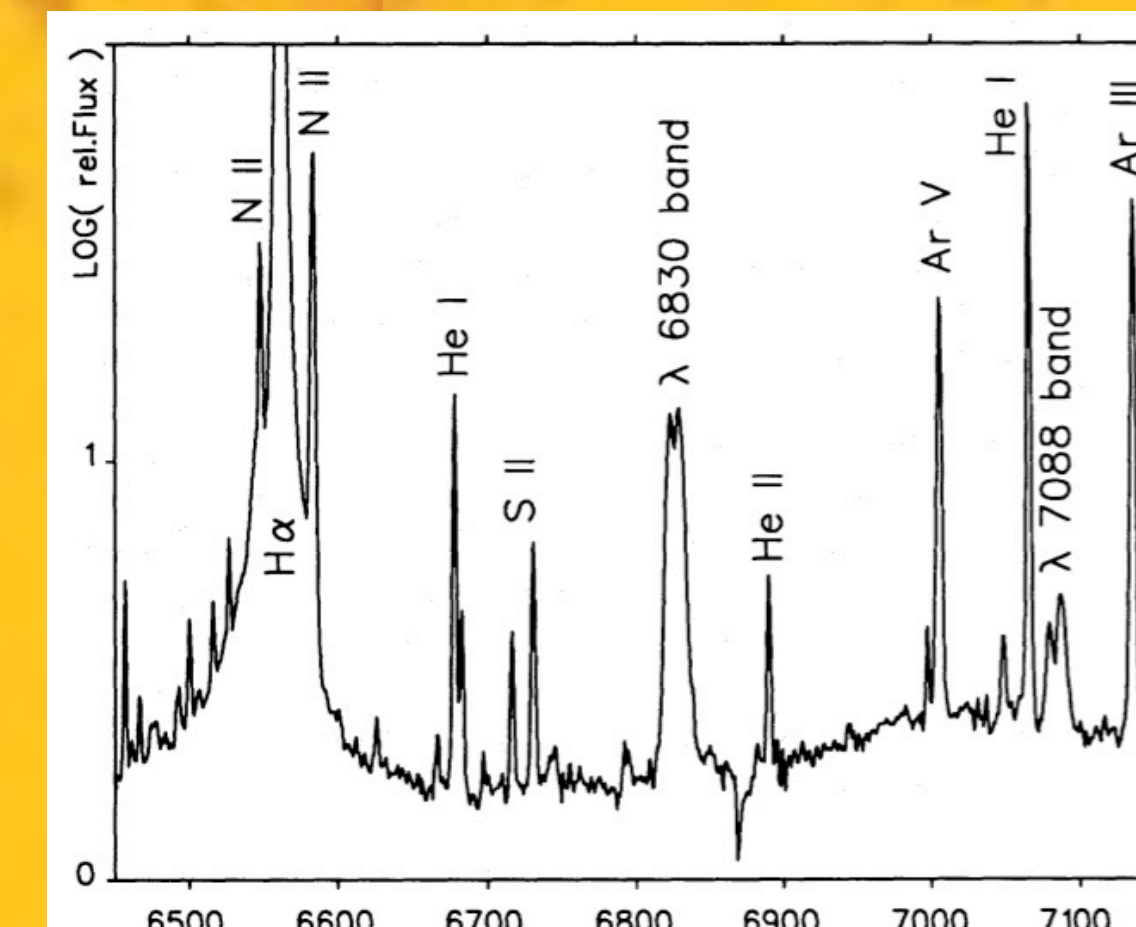

Fig.1. Raman scattered emission bands in the symbiotic star V1016 Cyg. The spectrum was obtained on the 1.93m telescope at the Observatoire de Haute Provence.

Observational confirmation of Raman scattered O VI 6825 & 7082 (Schmid 1989 A&A, 211, L31)

- Broad line profile

$$\lambda_o^{-1} = \lambda_i^{-1} - \lambda_\alpha^{-1}$$

Raman scattered λ_o is related with incident λ_i and hydrogen $\lambda_{Ly\alpha}$.

$$\frac{\Delta\lambda_o}{\lambda_o} = \left(\frac{\lambda_o}{\lambda_i}\right) \frac{\Delta\lambda_i}{\lambda_i}$$

For O VI 1032 and 6825 (λ_o/λ_i) = 6.6

DOUBLE PEAKED PROFILE

- Some symbiotic stars show double peaked profile of Raman scattered O VI 6825
- Probably due to incident double peaked nature of O VI 1032, which originates from hot ionized region around white dwarf.
- A possible explanation is rotating accretion disk. The velocity separation suggests few AU scale of O IV region.

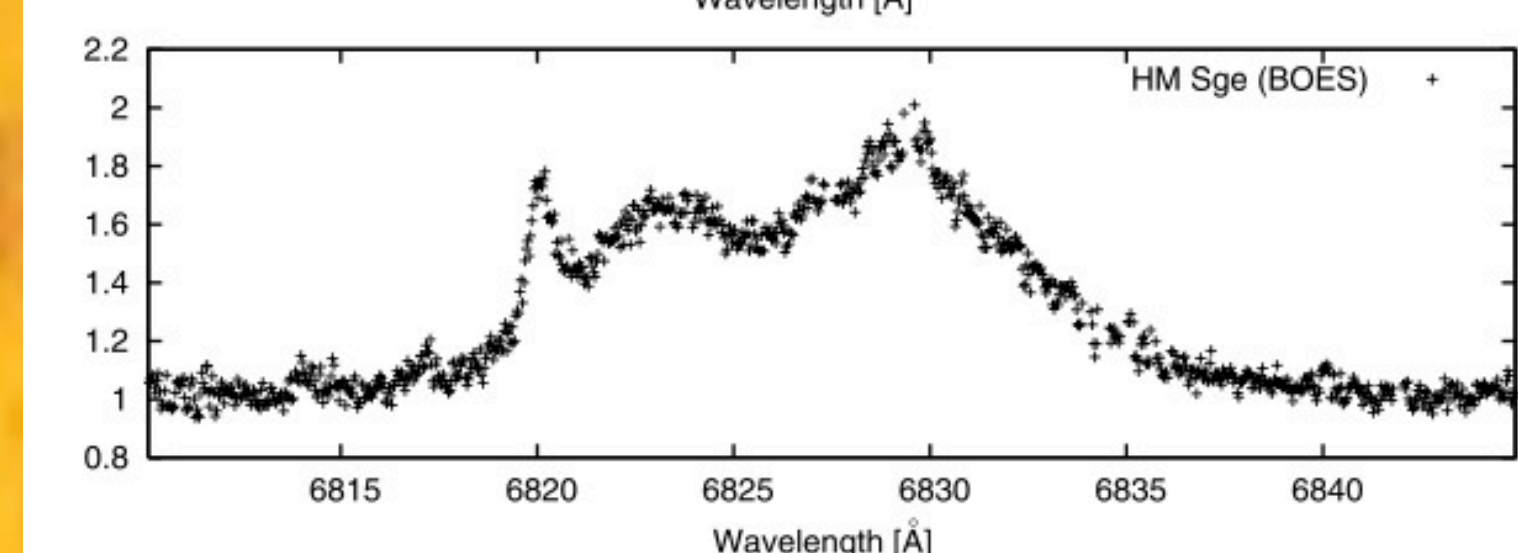
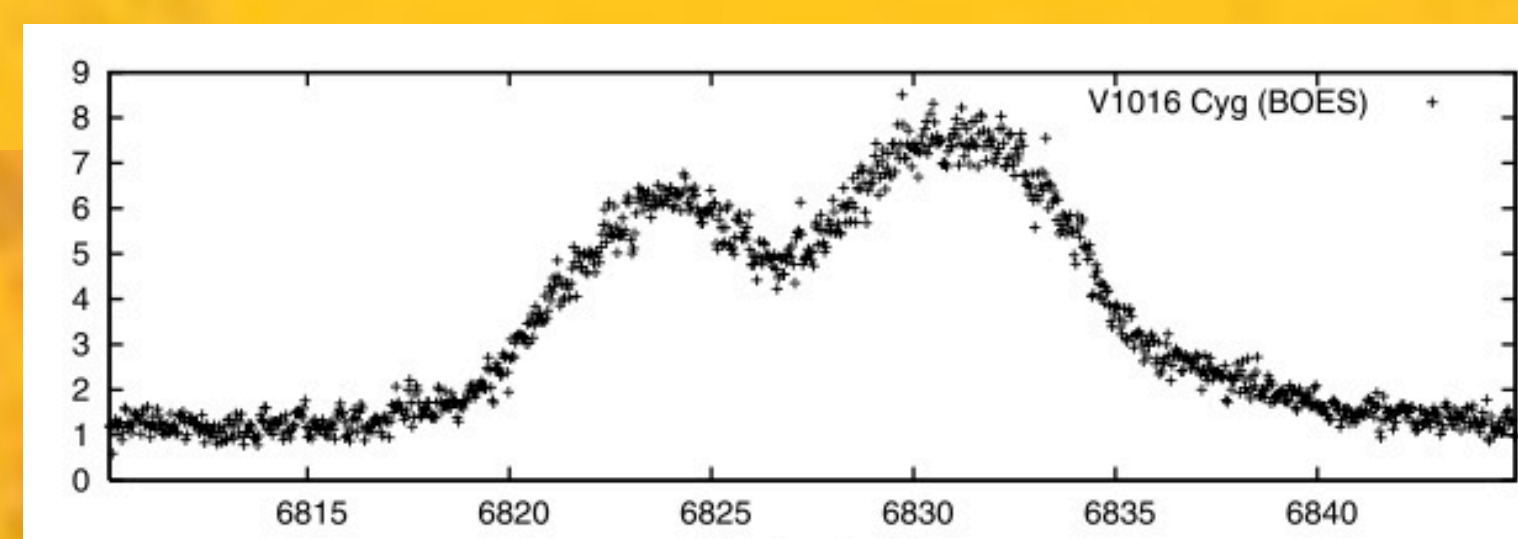
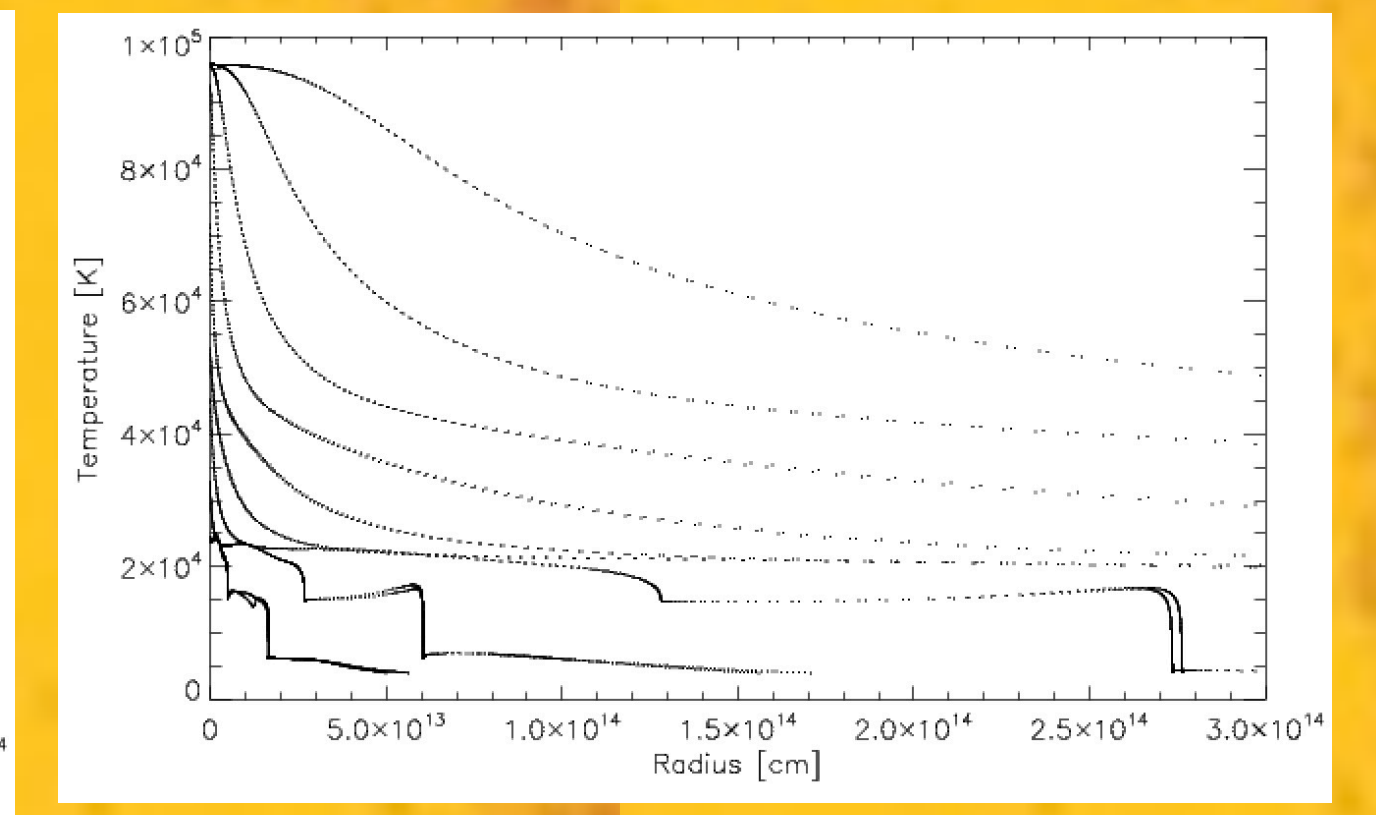
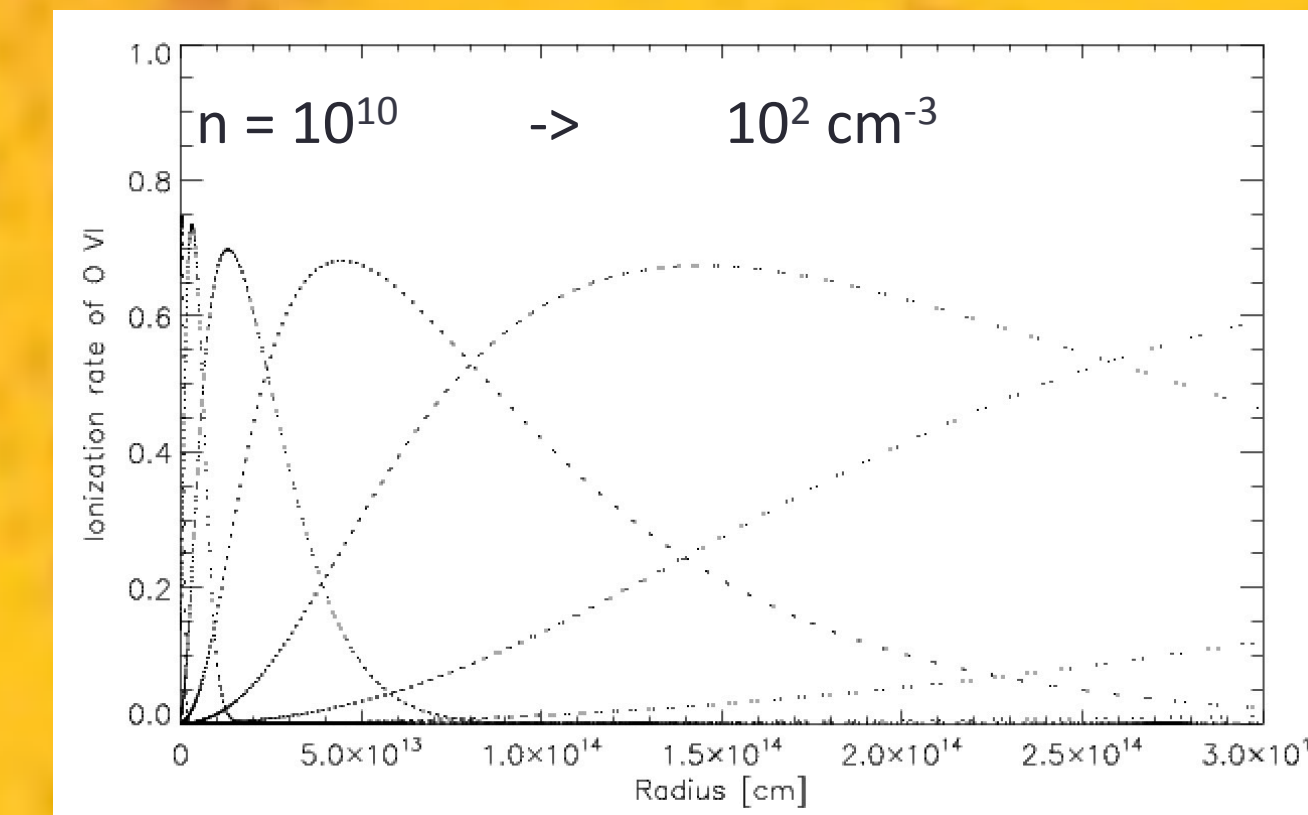

FIG. 1.—Parts of spectra around 6825 Å of the symbiotic stars V1016 Cyg and HM Sge obtained with the Bohyunsan Optical Echelle Spectrograph (BOES). The vertical scale is normalized by the local continuum. The peak separation is ~ 48 km s^{-1} for V1016 Cyg and ~ 41 km s^{-1} for HM Sge. The full widths at zero intensities are 166 and 161 km s^{-1} for V1016 Cyg and HM Sge, respectively.

Observation of double peaked Raman scattered O VI 6825 profile (Lee & Kang 2007, ApJ, 669, 1156).

RESULTS

- Varying H density (n) $10^2 - 10^{10}$ cm^{-3}



→ AU (1.5×10^{13} cm) scale ionized O VI region is made around H density of 10^8 cm^{-3}

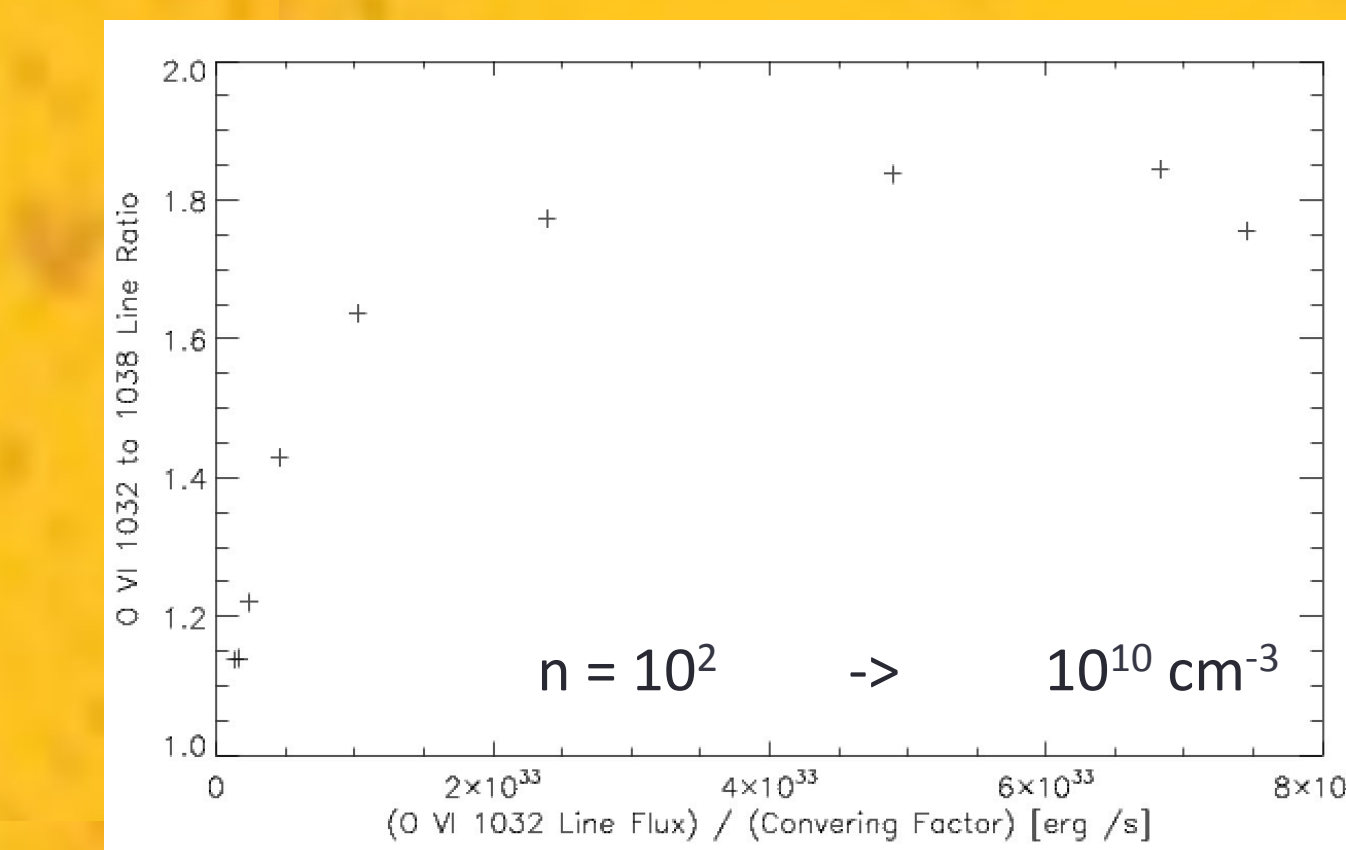

→ For high density cases, O VI 1032 to 1038 ratio is ~ 1.8 and line strength $\sim 10^{34}$ erg / s. But the covering factor (thickness of disk) can change the strength.

- Radial structure of accretion disk for H density of 10^8 cm^{-3}

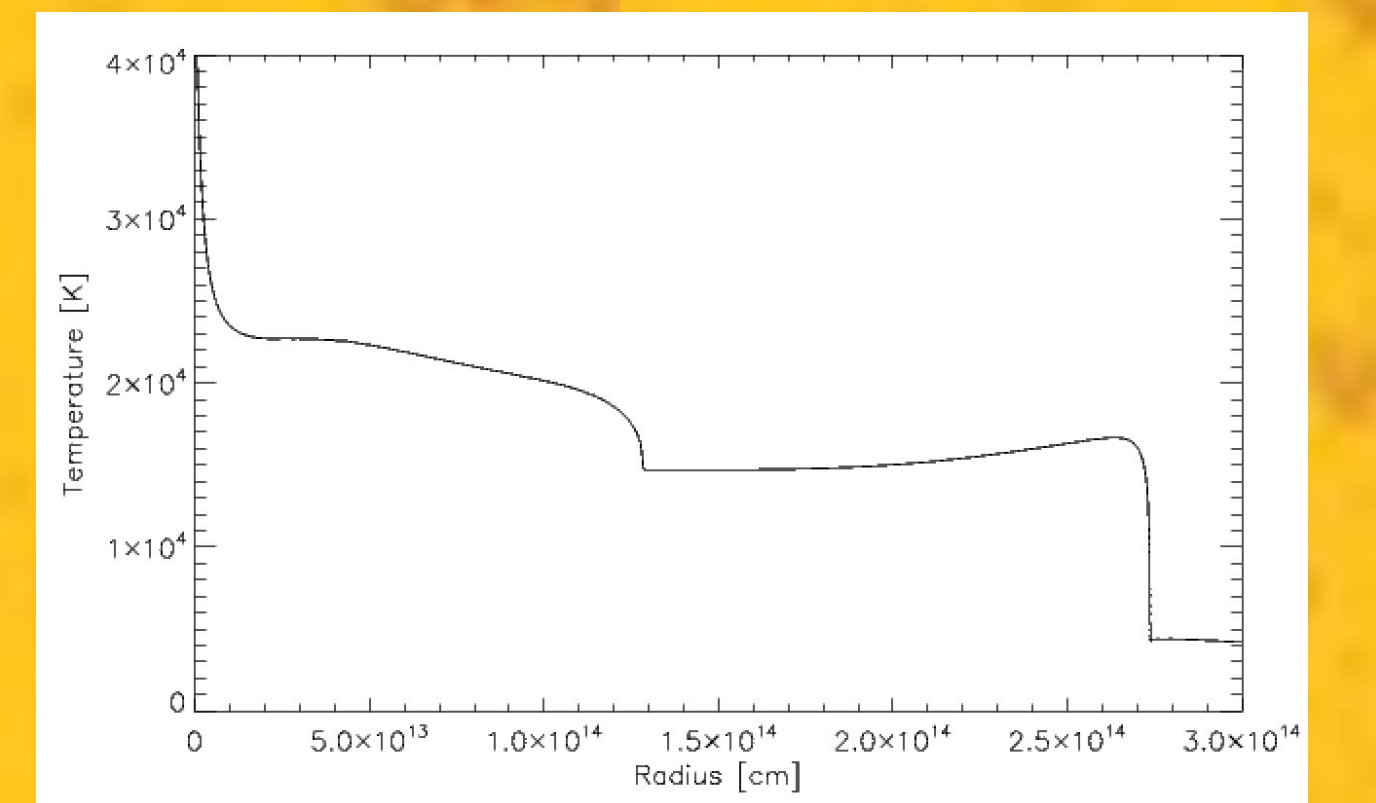
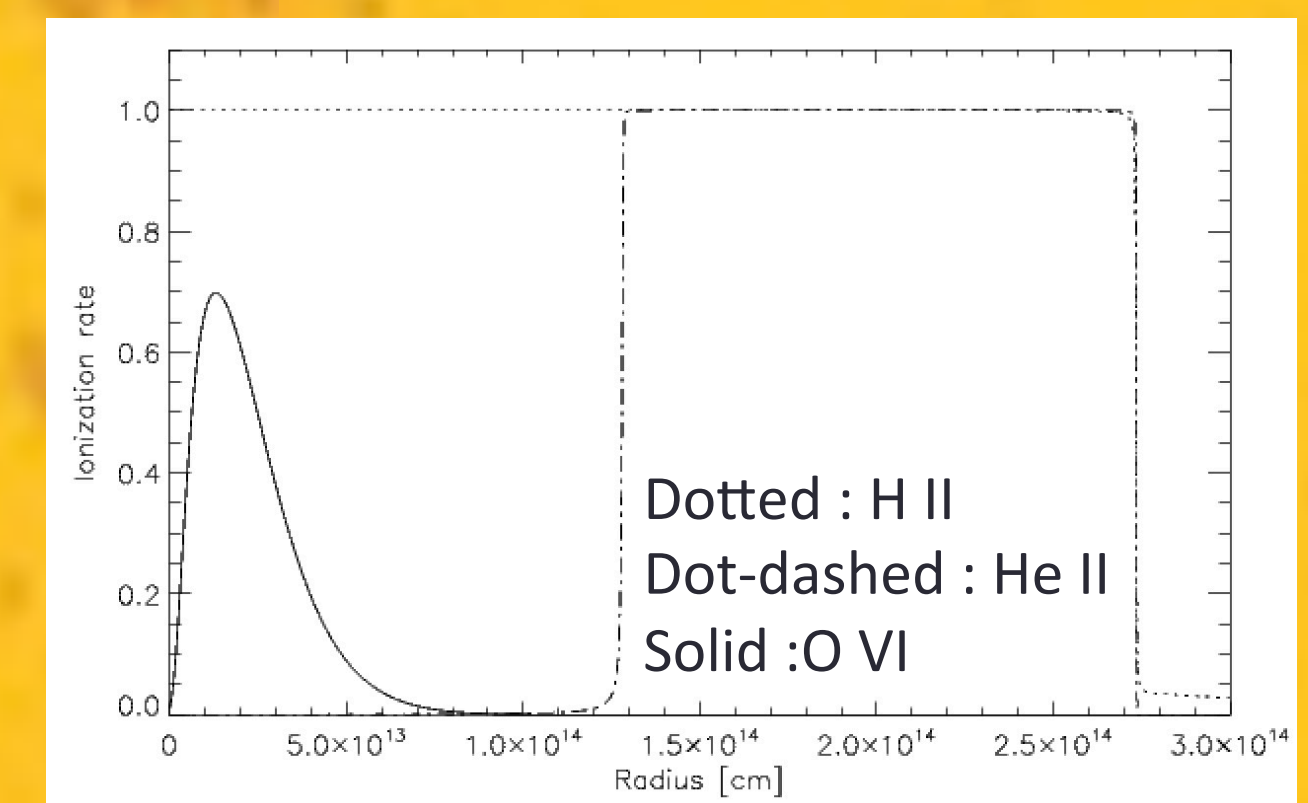

NOTES

- Even though we accept the input parameters, there are lots of simplifications such as density profile, thickness, and abundance which are hardly known.
- However, Raman scattering and its comparison with cloudy may give a clue to look into the innermost part of symbiotic star.
- CASS is a brand of Korean beer (www.cass.co.kr). It's a kind of a pale lager with an 4.5% ABV.